

# PRO-FIN WEATHERSTRIPPING

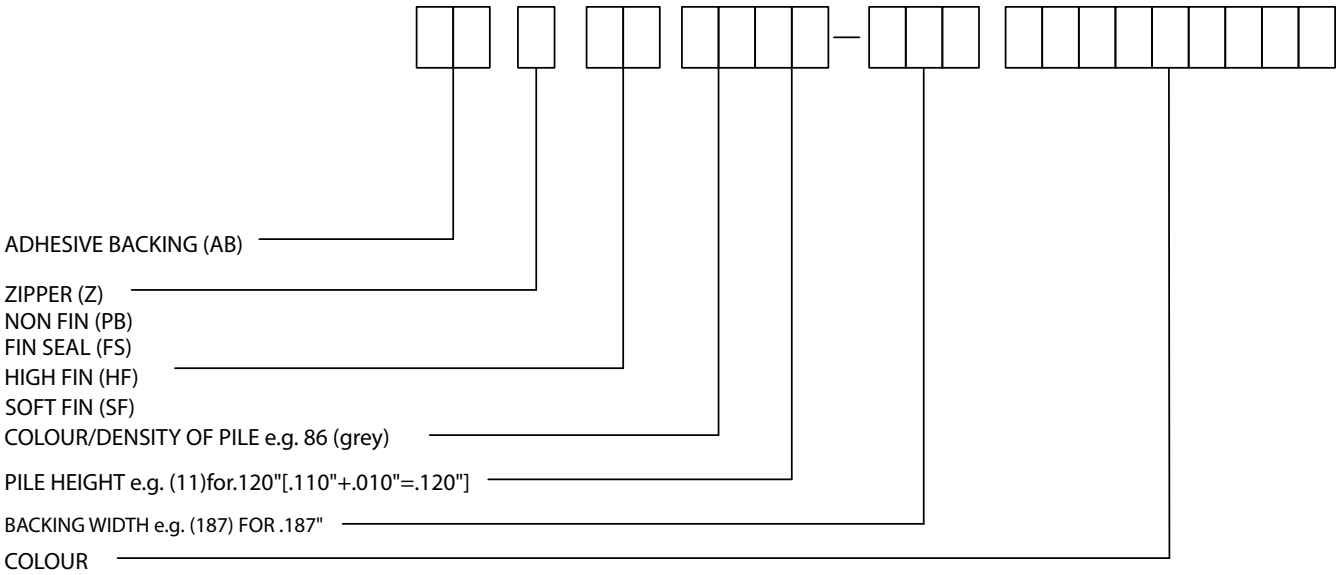

Pile heights from .10" to .50"  
 Recommended compression: 10 – 20%

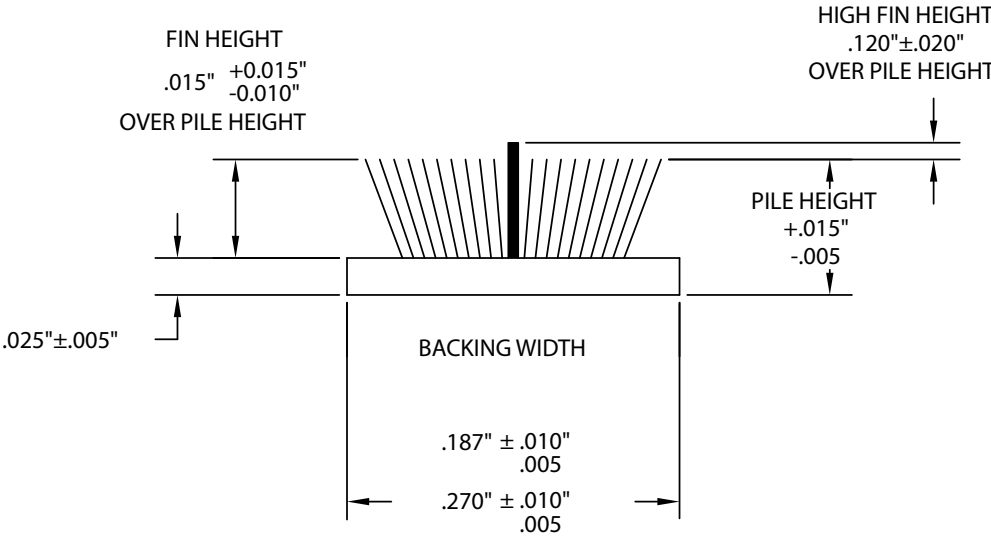

Custom widths available for volume purchases.

# PRO-FIN ZIPPER PILE WEATHERSTRIPPING

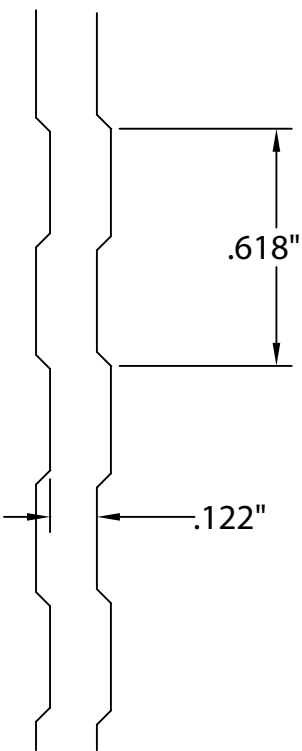
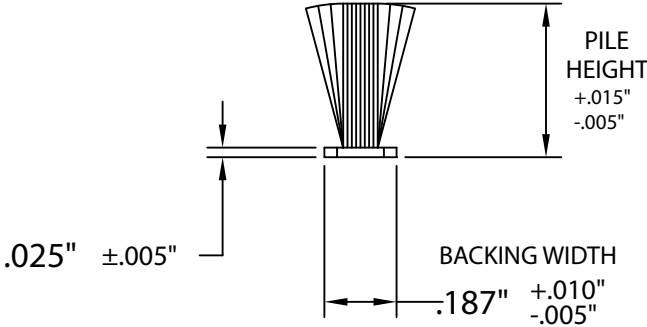

Actual Size

.187"

**RETROFIT WEATHER SEALS FOR WINDOWS AND DOORS**

**Use on:**

- Residential homes
- Real estate management
- Military bases
- Universities
- Hotels

*See last page of this document for details.*

# PRO-FIN ZIPPER PILE WEATHERSTRIPPING

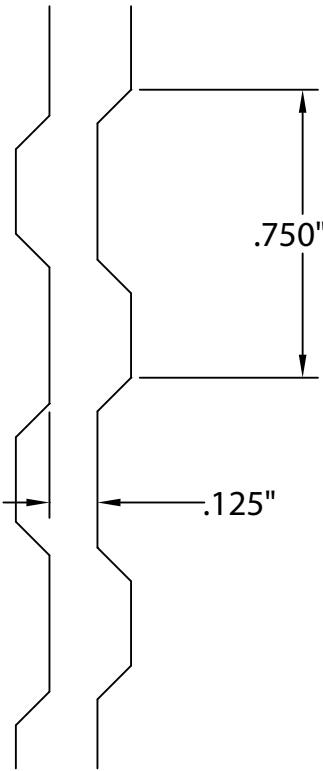
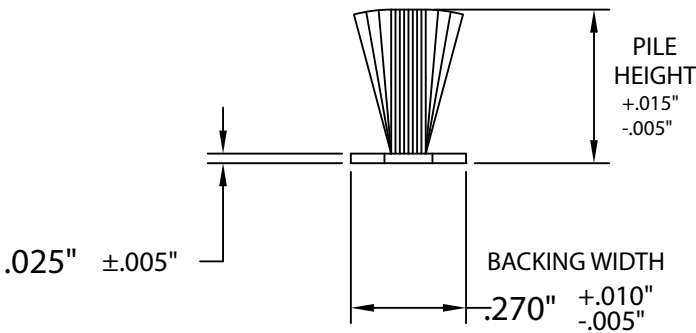

Actual Size

.270"

### RETROFIT WEATHER SEALS FOR WINDOWS AND DOORS

- Use on:**
- Residential homes
  - Real estate management
  - Military bases
  - Universities
  - Hotels

*See last page of this document for details.*



## RETROFIT WEATHER SEALS FOR WINDOWS AND DOORS

**REDUCE AIR, WATER, NOISE, DUST, MOLD & INSECTS**

### **Easy Insert Zipperpile**

- 4 widths cover all residential and commercial applications
- Pile heights ranging from 1/8" to 1/2", multiple colors
- Use in Aluminum, Wood, Vinyl or Fiberglass
- Application typically 75% faster insertion than traditional pile
- Product will go directly into or around corners
- Zipper construction allows easy insertion even in off size slots

### **Use on:**

- Residential homes
- Real estate management
- Military bases
- Universities
- Hotels

# SEALMAX

The Sealmax brand started in 2000; however, we have been manufacturing weatherseal and weatherstripping since 1931. Originally doing business as Schlegel Canada Inc., Sealmax has undergone many changes since then, but one thing remains the same — quality products for windows and doors.

#### **ADDRESS**

514 South Service Road East  
Oakville, ON L6J 2X6  
Telephone 1-866-458-3707  
Fax 1-905-845-6558

#### **EMAIL**

General Information: [info@sealmax.com](mailto:info@sealmax.com)  
Sales: [sales@sealmax.com](mailto:sales@sealmax.com)

[sealmax.com](http://sealmax.com)